

- NOTES:**
1. CONNECT TO EXISTING SERVICE USING APPROPRIATE SIZED COMPRESSION COUPLING.
 2. COPPER PIPING, UNIONS, COUPLINGS AND OTHER FITTINGS FOR COPPER TUBING SHALL BE THE COPPER SERVICE THREAD TYPE AND ALL SHALL COMPLY WITH NSF-61.
 3. CONTRACTOR TO ABANDON AND CAP EXISTING CORPORATION.
 4. DOUBLE STRAP SERVICE CLAMPS SHALL BE REQUIRED FOR CORPORATIONS LARGER THAN 1".

WATER SERVICE CONNECTION DETAIL
(COMPLETE IN PLACE)
N.T.S.

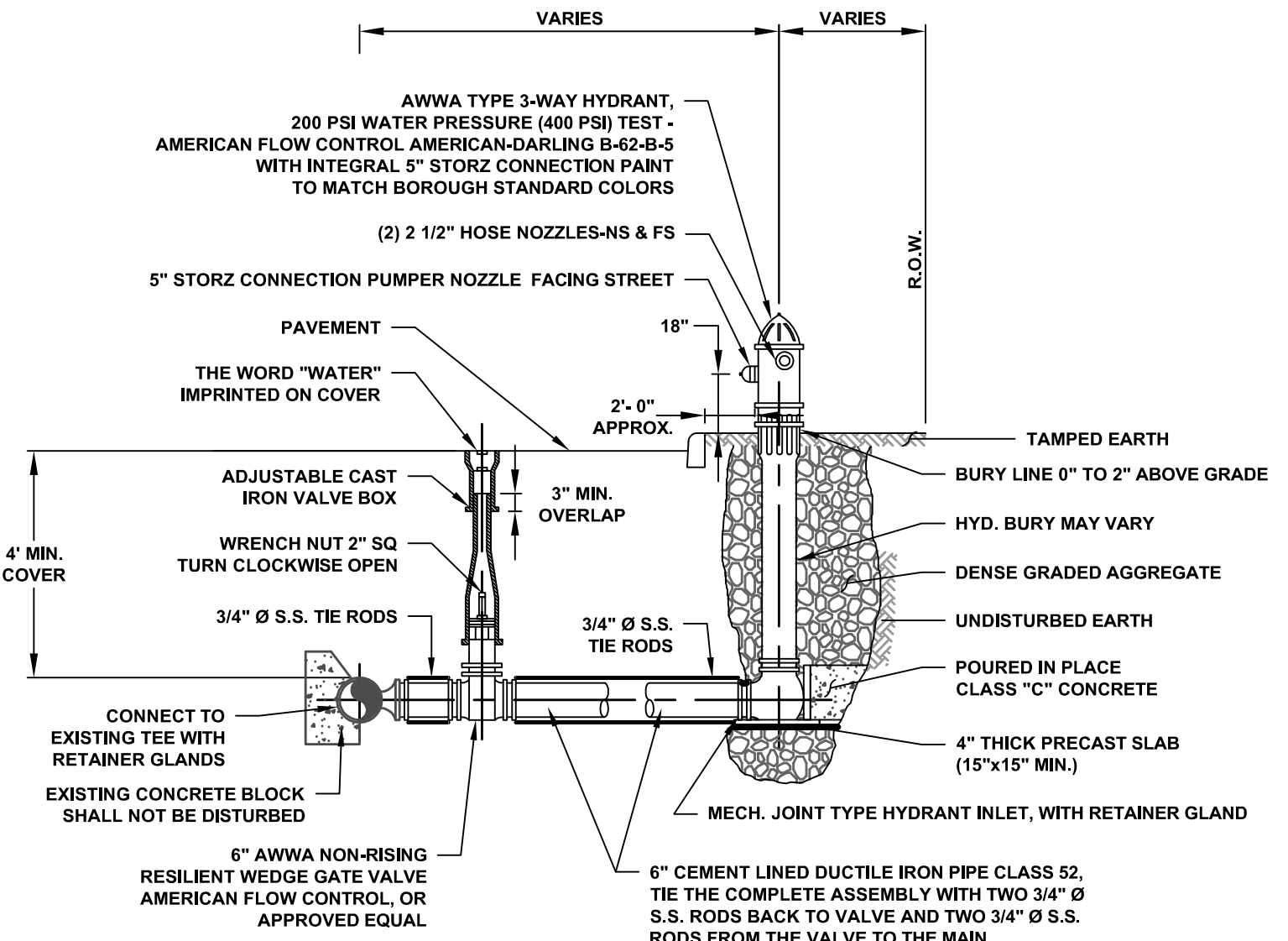

- NOTES:**
1. ALL EXPOSED METAL TO RECEIVE TWO COATS OF BITUMINOUS PAINT.
 2. USE CARE TO INSURE THAT DRAIN HOLE IS NOT PLUGGED.
 3. CONTRACTOR MUST RESTORE / REPLACE ANY DAMAGED EXISTING CURB.
 4. EXISTING HYDRANT, BREAKAWAY FLANGE, 90° BEND AND VALVE TO BE REMOVED AND RETURNED TO THE OWNER.
 5. CONTRACTOR TO PROTECT ALL EXISTING THRUST BLOCKS RESTRAINING EXISTING UTILITIES. EXISTING THRUST BLOCKS MUST NOT BE UNDERMINED OR DISTURBED. ANY DAMAGE TO THE THRUST RESTRAINTS MUST BE REPAIRED BY THE CONTRACTOR AT NO EXPENSE TO THE OWNER AND TO THE SATISFACTION OF THE ENGINEER.
 6. CONTRACTOR TO PROVIDE REDUCER WHEN EXISTING WATER MAIN HYDRANT TEE BRANCH AND PROPOSED 6" DIAMETER HYDRANT LATERAL ARE UNEQUAL DIAMETERS.

TYPICAL HYDRANT INSTALLATION DETAIL
N.T.S.

NOTICE
THIS DRAWING AND ALL INFORMATION CONTAINED HEREIN IS AUTHORIZED FOR USE ONLY BY THE PARTY FOR WHOM THE WORK WAS CONTRACTED OR TO WHOM IT IS CERTIFIED.
THIS DRAWING MAY NOT BE COPIED, REUSED, DISCLOSED, DISTRIBUTED, OR RELIED UPON FOR ANY OTHER PURPOSE WITHOUT THE WRITTEN CONSENT OF SUBURBAN CONSULTING ENGINEERS, INC.
PER N.J.A.C. ELECTRONIC SUBMISSIONS NOT CONTAINING A VALID DIGITAL SEAL OR PAPER COPIES NOT CONTAINING A RAISED SEAL ARE NOT ORIGINALS AND MAY HAVE BEEN ALTERED.
© COPYRIGHT 2019 SUBURBAN CONSULTING ENGINEERS, INC.™
ALL RIGHTS RESERVED

NO.	DESCRIPTION	DATE	BY:	CHK:
REV PER CONTRACT MODIFICATIONS	D	06/18/2019	RAC	
REV PER NJDEP REVIEW COMMENTS	C	02/19/2019	RAC	REW
REV PER NJDEP REVIEW COMMENTS	B	02/11/2019	RAC	REW
REV PER CONTRACT MODIFICATIONS	A	12/17/2018	RAC	REW
REVISIONS				

DRAWN BY:
RAC
05/01/2018
CHECKED BY:
MKM
05/01/2018
CHECKED BY:

ANDREW S. HOLT, PE
NJ PROFESSIONAL ENGINEER
LICENSE NO. 24GE03855400
(Signature)
DATE: 05/01/2018

SC ENGINEERS, INC.
SUBURBAN CONSULTING ENGINEERS, INC.
COA NO.: 24GA28037500
21M1100004200
- Civil Engineers - Municipal Engineers -
- Planners - Environmentalists - Land Surveyors -
- Landscape Architects -
96 US Highway 206, Suite 101 Flanders, NJ. 07836 - 973.398.1776
2430 Highway 34, Bldg. A Suite 1R Wall, N.J. 08736 - 732.282.1776
EXCELLENCE ♦ ECONOMY ♦ ENVIRONMENT

LEAD SERVICE WATER-LINE & FIRE HYDRANT REPLACEMENT RE-BID
BOROUGH OF GLEN RIDGE
ESSEX COUNTY, NEW JERSEY
CONSTRUCTION DETAILS I

PROJECT NUMBER:
SCE-8859.011
SCALE:
N.T.S.
SHEET 1 OF 10
REVISION D

E:\SCE\Glen Ridge - Lead Service and Hydrant\Re-bid\8859 Construction Details.dwg Jun 18, 2019 - 2:51pm rcarr SUBURBAN CONSULTING ENGINEERS, INC.

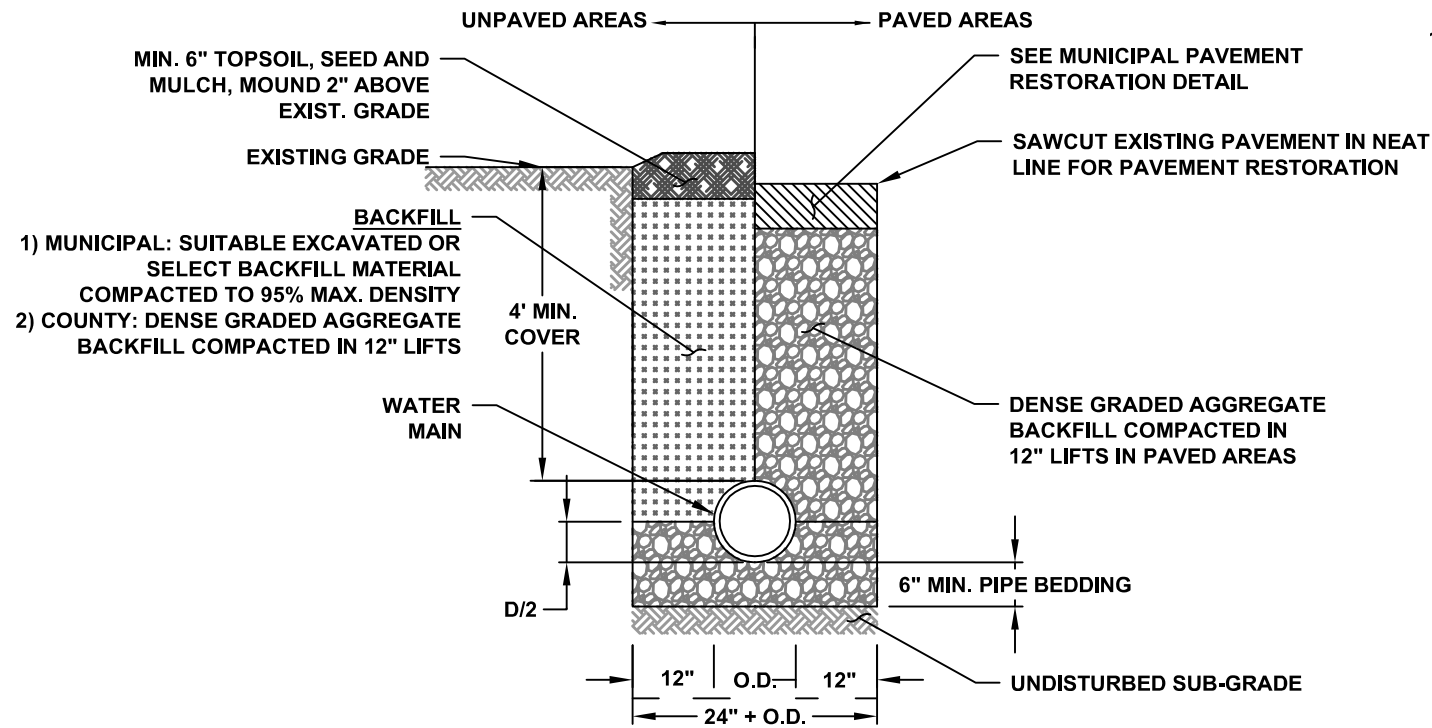

TYPICAL TRENCH DETAIL

N.T.S.

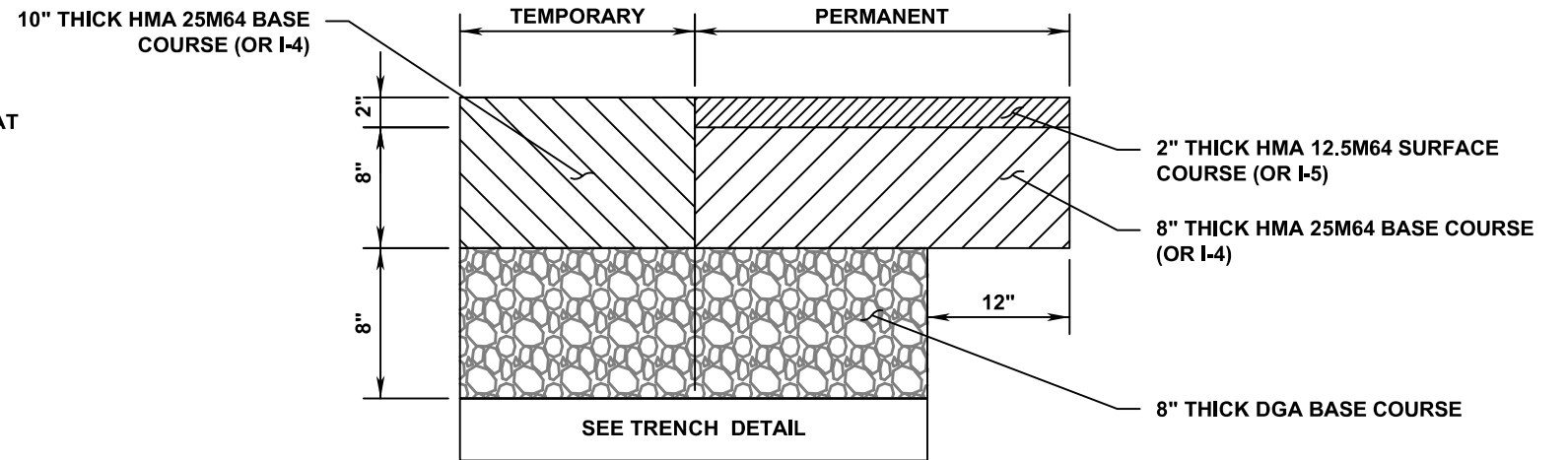

NOTES:

- 2007 NEW JERSEY D.O.T. STANDARD SPECIFICATIONS FOR ROADS AND BRIDGE CONSTRUCTION WITH AMENDMENTS SHALL GOVERN.
- WHEN THE EDGE OF TRENCH IS WITHIN 4' OR LESS FROM THE EXISTING CURB, FULL DEPTH PAVEMENT SHALL BE CONSTRUCTED.
- ALL EXCAVATED UNSUITABLE MATERIAL SHALL BE REMOVED AND DISPOSED OF AT THE UTILITY AND/OR CONTRACTOR'S EXPENSE.
- TEMPORARY PAVEMENT REPLACEMENT SHALL BE 10 INCHES OF HMA 25M64 BASE COURSE OR I-4, COMPACTED IN 5" LIFTS.
- AFTER (3) MONTHS OR AS DIRECTED BY THE COUNTY ENGINEER OR AUTHORIZED REPRESENTATIVE, THE TOP TWO (2) INCHES OF TRENCH RESTORATION PAVEMENT SHALL BE MILLED ONE (1) FOOT WIDER THAN TRENCH ON EACH SIDE.
- HMA SURFACE COURSE INSTALLATION SHALL INCLUDE ALL NECESSARY SAWCUTTING, MILLING, TACK COAT, HMA 12.5M64, SURFACE COURSE, 2" THICK, PAVING, AND ALL REQUIRED APPURTENANCES.
- TRENCHES SHALL BE SAWCUT AS INDICATED IN THIS DRAWING. BUTT JOINTS ARE NOT ALLOWED.
- TRAFFIC STRIPES AND TRAFFIC MARKINGS ARE TO BE REPLACED WITH TRAFFIC STRIPES, LONG LIFE AND TRAFFIC MARKINGS, THERMOPLASTIC.

ESSEX COUNTY PAVEMENT RESTORATION DETAIL

BLOOMFIELD AVE, RIDGEWOOD AVE, BAY AVE, WATCHUNG AVE, PORTIONS OF HIGHLAND AVE, & PORTIONS OF BELLEVILLE AVE

N.T.S.

PAVEMENT RESTORATION NOTES:

- LIMIT OF PAVEMENT IS BASED ON THE FOLLOWING CRITERIA:
 - A. WATER MAIN AND HYDRANT LINES - 3' WIDE TRENCH
 - B. SERVICE CONNECTIONS - 30" WIDE TRENCH
 - C. NO SEPARATE PAYMENT WILL BE MADE FOR RESTORATION EXCEEDING TRENCH WIDTHS
- FOR RESTORATION WITHIN LIMITS OF PROJECT AREA:
 - A. TEMPORARY RESTORATION:
 - TEMPORARY RESTORATION OF ALL MUNICIPAL ROADS SHALL CONSIST OF HMA 25M64, BASE COURSE, 8" MINIMUM THICKNESS OR TO MATCH EXISTING.
 - THE CONTRACTOR SHALL BE RESPONSIBLE FOR TRENCH SETTLEMENT AND SHALL PLACE ADDITIONAL HMA BASE COURSE MATERIAL AS NECESSARY.
- WHERE NEW PERMANENT PAVEMENT WILL BE CONSTRUCTED WITHIN TWO FEET OF THE EXISTING EDGE OF PAVEMENT OR EXISTING FACE OF CURB, MILLING AND PAVING SHOULD EXTEND TO THE EXISTING EDGE OF PAVEMENT OR FACE OF CURB. PAYMENT FOR THIS WORK SHALL BE INCLUDED IN THE HMA SURFACE COURSE PAVEMENT BID ITEM.
- PAVEMENT TO BE INSTALLED IN NO GREATER THAN 3" LIFTS.
- TACK COAT/JOINT SEALANT, RC-70, TO BE APPLIED TO ALL JOINTS AND EXISTING STRUCTURES PRIOR TO PAVING ON ALL COUNTY AND LOCAL ROADS. NJ STATE ROADS SHALL RECEIVE RC-70 ON ALL HORIZONTAL JOINTS AND EXISTING STRUCTURES AND A POLYMERIZED JOINT SEALANT ON ALL VERTICAL JOINTS.
- IT IS THE OBLIGATION OF THE CONTRACTOR TO MAKE SUBSURFACE CONDITION EVALUATIONS PRIOR TO SUBMITTING A PROPOSAL.

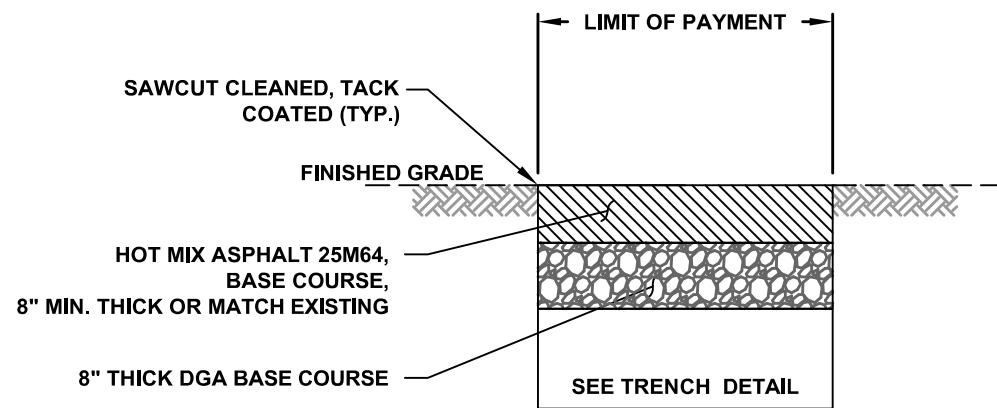

MUNICIPAL PAVEMENT RESTORATION DETAIL

N.T.S.

NOTICE

THIS DRAWING AND ALL INFORMATION CONTAINED HEREIN IS AUTHORIZED FOR USE ONLY BY THE PARTY FOR WHOM THE WORK WAS CONTRACTED OR TO WHOM IT IS CERTIFIED.

THIS DRAWING MAY NOT BE COPIED, REUSED, DISCLOSED, DISTRIBUTED, OR RELIED UPON FOR ANY OTHER PURPOSE WITHOUT THE WRITTEN CONSENT OF SUBURBAN CONSULTING ENGINEERS, INC.

PER N.J.A.C. ELECTRONIC SUBMISSIONS NOT CONTAINING A VALID DIGITAL SEAL OR PAPER COPIES NOT CONTAINING A RAISED SEAL ARE NOT ORIGINALS AND MAY HAVE BEEN ALTERED.

© COPYRIGHT 2019 SUBURBAN CONSULTING ENGINEERS, INC.™

ALL RIGHTS RESERVED

NO.	DESCRIPTION	DATE	BY:	CHK:
REV PER CONTRACT MODIFICATIONS	D	06/18/2019	RAC	
REV PER NJDEP REVIEW COMMENTS	C	02/19/2019	RAC	REW
REV PER NJDEP REVIEW COMMENTS	B	02/11/2019	RAC	REW
REV PER CONTRACT MODIFICATIONS	A	12/17/2018	RAC	REW
REVISIONS				

DRAWN BY:

RAC

05/01/2018

CHECKED BY:

MKM

05/01/2018

CHECKED BY:

ANDREW S. HOLT, PE
NJ PROFESSIONAL ENGINEER
LICENSE NO. 24GE03855400



DATE: 05/01/2018

SE SUBURBAN CONSULTING ENGINEERS, INC.

COA NO.: 24GA28037500
21M1100004200

- Civil Engineers - Municipal Engineers -
- Landscape Architects -
- Planners - Environmentalists - Land Surveyors -

96 US Highway 206, Suite 101 Flanders, N.J. 07836 - 973.398.1776

2430 Highway 34, Bldg. A Suite 1R Wall, N.J. 08736 - 732.282.1776

EXCELLENCE ♦ ECONOMY ♦ ENVIRONMENT

LEAD SERVICE WATER-LINE & FIRE HYDRANT REPLACEMENT RE-BID
BOROUGH OF GLEN RIDGE
ESSEX COUNTY, NEW JERSEY

CONSTRUCTION DETAILS II

PROJECT NUMBER:
SCE-8859.011

SCALE:
N.T.S.

SHEET 2 OF 10

REVISION D

CONSTRUCTION PHASE	HOUSE NUMBER	STREET NAME	REPORTED SERVICE SIZE	NOTES
	3	APPLETON PLACE	1"	
	4	APPLETON PLACE	1"	
	10	APPLETON PLACE	1"	
	15	APPLETON PLACE	1"	
	16	APPLETON PLACE	1"	
	19	APPLETON PLACE	1"	
	22	APPLETON PLACE	1"	
	25	APPLETON PLACE	1"	
	26	APPLETON PLACE	1"	
	27	APPLETON PLACE	1/2"	
	29	APPLETON PLACE	1"	
	30	APPLETON PLACE	1"	
	7	APPLETON ROAD	1"	
	9	APPLETON ROAD	1"	
	11	APPLETON ROAD	1"	
	14	APPLETON ROAD	1"	
	16	APPLETON ROAD	3/4"	
	18	APPLETON ROAD	1"	
	20	APPLETON ROAD	3/4"	
	21	APPLETON ROAD	1"	
	22	APPLETON ROAD	1"	
	24	APPLETON ROAD	1"	
	26	APPLETON ROAD	3/4"	
	27	APPLETON ROAD	1"	
	28	APPLETON ROAD	1"	
	29	APPLETON ROAD	1"	
	30	APPLETON ROAD	1"	
	31	APPLETON ROAD	1"	
	32	APPLETON ROAD	1"	
	33	APPLETON ROAD	1"	
	34	APPLETON ROAD	1"	
	35	APPLETON ROAD	1"	
	36	APPLETON ROAD	1"	
	22	BALDWIN STREET	1"	ADDRESS LOCATED IN MONTCLAIR
	53	BENSON STREET	1"	
	55	BENSON STREET	1"	
	59	BENSON STREET	1"	
	60	BENSON STREET	1"	
	64	BENSON STREET	1"	
	68	BENSON STREET	1"	
	72	BENSON STREET	1"	
	77	BENSON STREET	1"	
	51	CLARK STREET	1"	
	52	CLARK STREET	1"	
	53	CLARK STREET	1/2"	
	54	CLARK STREET	3/4"	
	56	CLARK STREET	1/2"	
	57	CLARK STREET	1"	
	58	CLARK STREET	1"	
	60	CLARK STREET	1"	
	61	CLARK STREET	1/2"	

CONSTRUCTION PHASE	HOUSE NUMBER	STREET NAME	REPORTED SERVICE SIZE	NOTES
	62	CLARK STREET	1"	
	64	CLARK STREET	1/2"	
	65	CLARK STREET	1/2"	
	66	CLARK STREET	3/4"	
	67	CLARK STREET	1/2"	
	70	CLARK STREET	1/2"	
	100	CLARK STREET	1/4"	
	103	CLARK STREET	3/4"	
	104	CLARK STREET	1"	
	108	CLARK STREET	1"	
	111	CLARK STREET	1"	
	114	CLARK STREET	1"	
	117	CLARK STREET	1"	
	1	CLINTON ROAD	1"	
	2	CLINTON ROAD	1"	
	6	CLINTON ROAD	1"	
	7	CLINTON ROAD	1"	
	14	CLINTON ROAD	1/2"	
	25	CLINTON ROAD	1"	
	27	CLINTON ROAD	1"	
	28	CLINTON ROAD	1"	
	29	CLINTON ROAD	1"	
	31	CLINTON ROAD	1"	
	32	CLINTON ROAD	1"	
	34	CLINTON ROAD	1"	
	36	CLINTON ROAD	1"	
	37	CLINTON ROAD	1"	
	38	CLINTON ROAD	1"	
	39	CLINTON ROAD	1"	
	41	CLINTON ROAD	1"	
	44	CLINTON ROAD	1"	
	49	CLINTON ROAD	1"	
	50	CLINTON ROAD	1"	
	61	CLINTON ROAD	1"	
	64	CLINTON ROAD	1"	
	40	GLEN RIDGE AVENUE	1"	
	50	GLEN RIDGE AVENUE	1"	
	52	GLEN RIDGE AVENUE	3/4"	
	54	GLEN RIDGE AVENUE	1"	
	58	GLEN RIDGE AVENUE	1"	
	67	GLEN RIDGE AVENUE	1"	
	68	GLEN RIDGE AVENUE	1"	
	70	GLEN RIDGE AVENUE	1"	
	72	GLEN RIDGE AVENUE	1"	
	73	GLEN RIDGE AVENUE	1/2"	
	76	GLEN RIDGE AVENUE	1"	
	80	GLEN RIDGE AVENUE	1"	
	85	GLEN RIDGE AVENUE	1"	
	88	GLEN RIDGE AVENUE	1"	
	89	GLEN RIDGE AVENUE	1"	
	92	GLEN RIDGE AVENUE	1"	

NOTICE
 THIS DRAWING AND ALL INFORMATION CONTAINED HEREIN IS AUTHORIZED FOR USE ONLY BY THE PARTY FOR WHOM THE WORK WAS CONTRACTED OR TO WHOM IT IS CERTIFIED.
 THIS DRAWING MAY NOT BE COPIED, REUSED, DISCLOSED, DISTRIBUTED, OR RELIED UPON FOR ANY OTHER PURPOSE WITHOUT THE WRITTEN CONSENT OF SUBURBAN CONSULTING ENGINEERS, INC.
 PER N.J.A.C. ELECTRONIC SUBMISSIONS NOT CONTAINING A VALID DIGITAL SEAL OR PAPER COPIES NOT CONTAINING A RAISED SEAL ARE NOT ORIGINALS AND MAY HAVE BEEN ALTERED.
 © COPYRIGHT 2019 SUBURBAN CONSULTING ENGINEERS, INC.™
 ALL RIGHTS RESERVED

REV PER CONTRACT MODIFICATIONS	NO.	DATE:	BY:	CHK:
REV PER CONTRACT MODIFICATIONS	D	06/18/2019	RAC	REW
REV PER NJDEP REVIEW COMMENTS	C	02/19/2019	RAC	REW
REV PER NJDEP REVIEW COMMENTS	B	02/11/2019	RAC	REW
REV PER CONTRACT MODIFICATIONS	A	12/17/2018	RAC	REW
DESCRIPTION	NO.	DATE:	BY:	CHK:
REVISIONS				

DRAWN BY:
RAC
05/01/2018
 CHECKED BY:
MKM
05/01/2018
 CHECKED BY:

ANDREW S. HOLT, PE
 NJ PROFESSIONAL ENGINEER
 LICENSE NO. 24GE03855400

 DATE: 05/01/2018

SE SUBURBAN CONSULTING ENGINEERS, INC.
 COA NO.: 24GA28037500
 21MFI00004200
 - Civil Engineers - Municipal Engineers -
 - Landscape Architects -
 - Planners - Environmentalists - Land Surveyors -
 96 US Highway 206, Suite 101 Flanders, NJ, 07836 - 973.398.1776
 2430 Highway 34, Bldg. A Suite 1R Wall, N.J. 08736 - 732.282.1776
 EXCELLENCE ♦ ECONOMY ♦ ENVIRONMENT

LEAD SERVICE WATER-LINE & FIRE HYDRANT REPLACEMENT RE-BID
BOROUGH OF GLEN RIDGE
ESSEX COUNTY, NEW JERSEY
SERVICE SCHEDULE I

PROJECT NUMBER:
SCE-8859.011
 SCALE:
N.T.S.
 SHEET 3 OF 10
 REVISION D

CONSTRUCTION PHASE	HOUSE NUMBER	STREET NAME	REPORTED SERVICE SIZE	NOTES
	93	GLEN RIDGE AVENUE	1"	
	97	GLEN RIDGE AVENUE	1"	
	103	GLEN RIDGE AVENUE	1"	
	106	GLEN RIDGE AVENUE	1"	
	107	GLEN RIDGE AVENUE	1"	
	109	GLEN RIDGE AVENUE	1"	
	113	GLEN RIDGE AVENUE	1"	
	117	GLEN RIDGE AVENUE	1"	
	119	GLEN RIDGE AVENUE	1"	
	121	GLEN RIDGE AVENUE	1"	
	42-44	GLEN RIDGE AVENUE	1"	
	77-79	GLEN RIDGE AVENUE	1"	
	41	GLEN RIDGE PARKWAY	1"	
	42	GLEN RIDGE PARKWAY	1"	
	43	GLEN RIDGE PARKWAY	1"	
	44	GLEN RIDGE PARKWAY	1"	
	45	GLEN RIDGE PARKWAY	1"	
	46	GLEN RIDGE PARKWAY	3/4"	
	47	GLEN RIDGE PARKWAY	1"	
	48	GLEN RIDGE PARKWAY	1"	
	69	GLEN RIDGE PARKWAY	1"	
	16	SHERMAN AVENUE	1"	
	30	SHERMAN AVENUE	1"	
	36	SHERMAN AVENUE	1"	
	42	SHERMAN AVENUE	1"	
	46	SHERMAN AVENUE	1"	
	50	SHERMAN AVENUE	1"	
	60	SHERMAN AVENUE	1"	
	70	SHERMAN AVENUE	1"	
	77	SHERMAN AVENUE	1"	
	81	SHERMAN AVENUE	1"	
	96	SHERMAN AVENUE	1"	
	97	SHERMAN AVENUE	1"	
	100	SHERMAN AVENUE	1"	
	102	SHERMAN AVENUE	1"	
	104	SHERMAN AVENUE	1"	
	105	SHERMAN AVENUE	1"	
	106	SHERMAN AVENUE	1"	
	108	SHERMAN AVENUE	1"	
	109	SHERMAN AVENUE	1"	
	110	SHERMAN AVENUE	1"	
	137	SHERMAN AVENUE	1/2"	
	138	SHERMAN AVENUE	1"	
	139	SHERMAN AVENUE	1"	
	140	SHERMAN AVENUE	1"	
	141	SHERMAN AVENUE	1"	
	143	SHERMAN AVENUE	1"	
	146	SHERMAN AVENUE	1"	
	166	SHERMAN AVENUE	1"	
	168	SHERMAN AVENUE	1"	
	174	SHERMAN AVENUE	1"	

CONSTRUCTION PHASE	HOUSE NUMBER	STREET NAME	REPORTED SERVICE SIZE	NOTES
	186	SHERMAN AVENUE	1"	
	190	SHERMAN AVENUE	1"	
	194	SHERMAN AVENUE	1"	
	198	SHERMAN AVENUE	1"	
	219	SHERMAN AVENUE	1"	
	235	SHERMAN AVENUE	1"	
	237	SHERMAN AVENUE	1"	
	239	SHERMAN AVENUE	1"	
	15-17	SHERMAN AVENUE	1"	
	2	WILDWOOD TERRACE	1"	
	5	WILDWOOD TERRACE	1"	
	6	WILDWOOD TERRACE	3/4"	
	9	WILDWOOD TERRACE	1"	
	10	WILDWOOD TERRACE	1"	
	15	WILDWOOD TERRACE	1"	
	22	WILDWOOD TERRACE	1"	
	24	WILDWOOD TERRACE	1"	
	25	WILDWOOD TERRACE	1"	
	27	WILDWOOD TERRACE	1"	
	9	WINSOR PLACE	1"	
	12	WINSOR PLACE	1"	
	13	WINSOR PLACE	1"	
	14	WINSOR PLACE	1"	
	15	WINSOR PLACE	1"	
	16	WINSOR PLACE	1/2"	
	17	WINSOR PLACE	1/2"	
	20	WINSOR PLACE	1/2"	
	21	WINSOR PLACE	1"	
	22	WINSOR PLACE	1"	
	25	WINSOR PLACE	1"	
	26	WINSOR PLACE	1"	
	29	WINSOR PLACE	1/2"	
	30	WINSOR PLACE	1"	
	32	WINSOR PLACE	1"	
	40	WINSOR PLACE	1"	
	58	WINSOR PLACE	1"	
	64	WINSOR PLACE	1"	
	67	WINSOR PLACE	3/4"	
	68	WINSOR PLACE	1"	
	69	WINSOR PLACE	1"	
	71	WINSOR PLACE	1"	
	72	WINSOR PLACE	1"	
	73	WINSOR PLACE	1"	
	74	WINSOR PLACE	1"	
	75	WINSOR PLACE	1"	
	78	WINSOR PLACE	1"	
	79	WINSOR PLACE	1"	
	82	WINSOR PLACE	1"	
	83	WINSOR PLACE	1"	
	97	WINSOR PLACE	1"	

NOTICE
 THIS DRAWING AND ALL INFORMATION CONTAINED HEREIN IS AUTHORIZED FOR USE ONLY BY THE PARTY FOR WHOM THE WORK WAS CONTRACTED OR TO WHOM IT IS CERTIFIED.
 THIS DRAWING MAY NOT BE COPIED, REUSED, DISCLOSED, DISTRIBUTED, OR RELIED UPON FOR ANY OTHER PURPOSE WITHOUT THE WRITTEN CONSENT OF SUBURBAN CONSULTING ENGINEERS, INC.
 PER N.J.A.C. ELECTRONIC SUBMISSIONS NOT CONTAINING A VALID DIGITAL SEAL OR PAPER COPIES NOT CONTAINING A RAISED SEAL ARE NOT ORIGINALS AND MAY HAVE BEEN ALTERED.
 © COPYRIGHT 2019 SUBURBAN CONSULTING ENGINEERS, INC.™
 ALL RIGHTS RESERVED

REV PER CONTRACT MODIFICATIONS	NO.	DATE:	BY:	CHK:
REV PER CONTRACT MODIFICATIONS	D	06/18/2019	RAC	REW
REV PER NJDEP REVIEW COMMENTS	C	02/19/2019	RAC	REW
REV PER NJDEP REVIEW COMMENTS	B	02/11/2019	RAC	REW
REV PER CONTRACT MODIFICATIONS	A	12/17/2018	RAC	REW
REVISIONS				

DRAWN BY:
RAC
05/01/2018
 CHECKED BY:
MKM
05/01/2018
 CHECKED BY:

ANDREW S. HOLT, PE
 NJ PROFESSIONAL ENGINEER
 LICENSE NO. 24GE03855400

 DATE: 05/01/2018

SC ENGINEERS, INC.
 SUBURBAN CONSULTING ENGINEERS, INC.
 COA NO.: 24GA28037500
 21MFI00004200
 - Civil Engineers - Municipal Engineers -
 - Landscape Architects -
 - Planners - Environmentalists - Land Surveyors -
 96 US Highway 206, Suite 101 Flanders, N.J. 07836 - 973.398.1776
 2430 Highway 34, Bldg. A Suite 1R Wall, N.J. 08736 - 732.282.1776
 EXCELLENCE ♦ ECONOMY ♦ ENVIRONMENT

LEAD SERVICE WATER-LINE & FIRE HYDRANT REPLACEMENT RE-BID
BOROUGH OF GLEN RIDGE
ESSEX COUNTY, NEW JERSEY
SERVICE SCHEDULE II

PROJECT NUMBER:
SCE-8859.011
 SCALE:
N.T.S.
 SHEET 4 OF 10
 REVISION D

CONSTRUCTION PHASE	HOUSE NUMBER	STREET NAME	REPORTED SERVICE SIZE	NOTES
II	15	ARGYLE STREET	1"	
II	16	ARGYLE STREET	1"	
II	20	ARGYLE STREET	1"	
II	21	ARGYLE STREET	1"	
II	22	ARGYLE STREET	1"	
II	25	ARGYLE STREET	1"	
II	168	BAY AVENUE	1"	COUNTY ROUTE 654
II	172	BAY AVENUE	1"	COUNTY ROUTE 654
II	174	BAY AVENUE	1"	COUNTY ROUTE 654
II	176	BAY AVENUE	1"	COUNTY ROUTE 654
II	178	BAY AVENUE	1"	COUNTY ROUTE 654
II	190	BAY AVENUE	3/4"	COUNTY ROUTE 654
II	269	BAY AVENUE	1"	COUNTY ROUTE 654
II	271	BAY AVENUE	1"	COUNTY ROUTE 654
II	275	BAY AVENUE	1"	COUNTY ROUTE 654
II	277	BAY AVENUE	1"	COUNTY ROUTE 654
II	279	BAY AVENUE	1"	COUNTY ROUTE 654
II	281	BAY AVENUE	1"	COUNTY ROUTE 654
II	905	BLOOMFIELD AVENUE	1"	COUNTY ROUTE 506
II	2	HATHAWAY PLACE	1"	
II	5	HATHAWAY PLACE	1"	
II	6	HATHAWAY PLACE	1"	
II	7	HATHAWAY PLACE	1"	
II	8	HATHAWAY PLACE	1"	
II	10	HATHAWAY PLACE	1"	
II	11	HATHAWAY PLACE	1"	
II	14	HATHAWAY PLACE	1"	
II	15	HATHAWAY PLACE	1"	
II	17	HATHAWAY PLACE	1"	
II	20	HATHAWAY PLACE	1"	
II	32	HATHAWAY PLACE	1"	
II	35	HATHAWAY PLACE	1"	
II	37	HATHAWAY PLACE	1"	
II	39	HATHAWAY PLACE	1"	
II	40	HATHAWAY PLACE	3/4"	
II	7	HIGHLAND AVENUE	1"	COUNTY ROUTE 506
II	11	HIGHLAND AVENUE	1"	COUNTY ROUTE 506
II	15	HIGHLAND AVENUE	1"	COUNTY ROUTE 506
II	17	HIGHLAND AVENUE	1"	COUNTY ROUTE 506
II	63	HIGHLAND AVENUE	1"	COUNTY ROUTE 506
II	1	INNESS PLACE	1"	
II	2	INNESS PLACE	1"	
II	3	INNESS PLACE	1"	
II	4	INNESS PLACE	1"	
II	5	INNESS PLACE	1"	
II	6	INNESS PLACE	1"	
II	7	INNESS PLACE	1"	
II	8	INNESS PLACE	1"	
II	9	INNESS PLACE	1"	
II	10	INNESS PLACE	1"	
II	11	INNESS PLACE	1"	

CONSTRUCTION PHASE	HOUSE NUMBER	STREET NAME	REPORTED SERVICE SIZE	NOTES
II	12	INNESS PLACE	1"	
II	1	LAUREL PLACE	1"	
II	2	LAUREL PLACE	1"	
II	3	LAUREL PLACE	1"	
II	5	LAUREL PLACE	1"	
II	6	LAUREL PLACE	1"	
II	7	LAUREL PLACE	1"	
II	8	LAUREL PLACE	1"	
II	10	LAUREL PLACE	3/4"	
II	11	LAUREL PLACE	1"	
II	12	LAUREL PLACE	1"	
II	14	LAUREL PLACE	1"	
II	15	LAUREL PLACE	1"	
II	16	LAUREL PLACE	1"	
II	17	LAUREL PLACE	1"	
II	18	LAUREL PLACE	1"	
II	19	LAUREL PLACE	1"	
II	20	LAUREL PLACE	1"	
II	22	LAUREL PLACE	1"	
II	132	LINDEN AVENUE	1"	TAP LOCATED ON MIDLAND AVE
II	220	LINDEN AVENUE	1"	
II	221	LINDEN AVENUE	1"	
II	300	LINDEN AVENUE	1"	
II	1	MADISON STREET	1"	
II	5	MIDLAND AVENUE	1"	
II	7	MIDLAND AVENUE	1"	
II	8	MIDLAND AVENUE	1"	
II	9	MIDLAND AVENUE	1"	
II	10	MIDLAND AVENUE	1"	
II	11	MIDLAND AVENUE	1"	
II	12	MIDLAND AVENUE	1"	
II	14	MIDLAND AVENUE	1"	
II	14	MIDLAND AVENUE	1"	
II	15	MIDLAND AVENUE	1"	
II	16	MIDLAND AVENUE	1"	
II	17	MIDLAND AVENUE	1"	
II	19	MIDLAND AVENUE	1"	
II	20	MIDLAND AVENUE	3/4"	
II	23	MIDLAND AVENUE	1"	
II	25	MIDLAND AVENUE	1"	
II	26	MIDLAND AVENUE	1"	
II	27	MIDLAND AVENUE	1"	
II	28	MIDLAND AVENUE	1"	
II	30	MIDLAND AVENUE	1"	
II	32	MIDLAND AVENUE	1"	
II	34	MIDLAND AVENUE	1"	
II	41	MIDLAND AVENUE	1"	
II	43	MIDLAND AVENUE	1"	
II	44	MIDLAND AVENUE	1"	
II	45	MIDLAND AVENUE	1"	
II	46	MIDLAND AVENUE	1"	

NOTICE
 THIS DRAWING AND ALL INFORMATION CONTAINED HEREIN IS AUTHORIZED FOR USE ONLY BY THE PARTY FOR WHOM THE WORK WAS CONTRACTED OR TO WHOM IT IS CERTIFIED.
 THIS DRAWING MAY NOT BE COPIED, REUSED, DISCLOSED, DISTRIBUTED, OR RELIED UPON FOR ANY OTHER PURPOSE WITHOUT THE WRITTEN CONSENT OF SUBURBAN CONSULTING ENGINEERS, INC.
 PER N.J.A.C. ELECTRONIC SUBMISSIONS NOT CONTAINING A VALID DIGITAL SEAL OR PAPER COPIES NOT CONTAINING A RAISED SEAL ARE NOT ORIGINALS AND MAY HAVE BEEN ALTERED.
 © COPYRIGHT 2019 SUBURBAN CONSULTING ENGINEERS, INC.™
 ALL RIGHTS RESERVED

REV PER CONTRACT MODIFICATIONS	D	06/18/2019	RAC	REW
REV PER NJDEP REVIEW COMMENTS	C	02/19/2019	RAC	REW
REV PER NJDEP REVIEW COMMENTS	B	02/11/2019	RAC	REW
REV PER CONTRACT MODIFICATIONS	A	12/17/2018	RAC	REW
DESCRIPTION	NO.	DATE:	BY:	CHK:
REVISIONS				

DRAWN BY:
RAC
05/01/2018
 CHECKED BY:
MKM
05/01/2018
 CHECKED BY:

ANDREW S. HOLT, PE
 NJ PROFESSIONAL ENGINEER
 LICENSE NO. 24GE03855400

 DATE: 05/01/2018

SC SUBURBAN CONSULTING ENGINEERS, INC.
 COA NO.: 24GA28037500
 21MFI00004200
 - Civil Engineers - Municipal Engineers -
 - Landscape Architects -
 - Planners - Environmentalists - Land Surveyors -
 96 US Highway 206, Suite 101 Flanders, NJ, 07836 - 973.398.1776
 2430 Highway 34, Bldg. A Suite 1R Wall, NJ, 08736 - 732.282.1776
 EXCELLENCE ♦ ECONOMY ♦ ENVIRONMENT

LEAD SERVICE WATER-LINE & FIRE HYDRANT REPLACEMENT RE-BID
BOROUGH OF GLEN RIDGE
ESSEX COUNTY, NEW JERSEY
SERVICE SCHEDULE III

PROJECT NUMBER:
SCE-8859.011
 SCALE:
N.T.S.
 SHEET 5 OF 10
 REVISION D

CONSTRUCTION PHASE	HOUSE NUMBER	STREET NAME	REPORTED SERVICE SIZE	NOTES
II	48	MIDLAND AVENUE	1"	
II	49	MIDLAND AVENUE	1"	
II	50	MIDLAND AVENUE	1"	
II	51	MIDLAND AVENUE	1"	
II	52	MIDLAND AVENUE	1"	
II	54	MIDLAND AVENUE	1"	
II	55	MIDLAND AVENUE	1"	
II	56	MIDLAND AVENUE	1"	
II	57	MIDLAND AVENUE	1"	
II	59	MIDLAND AVENUE	1"	
II	60	MIDLAND AVENUE	1"	
II	62	MIDLAND AVENUE	1"	
II	63	MIDLAND AVENUE	3/4"	
II	64	MIDLAND AVENUE	1"	
II	65	MIDLAND AVENUE	1"	
II	66	MIDLAND AVENUE	3/4"	
II	67	MIDLAND AVENUE	3/4"	
II	74	MIDLAND AVENUE	1"	
II	76	MIDLAND AVENUE	3/4"	
II	78	MIDLAND AVENUE	1"	
II	81	MIDLAND AVENUE	3/4"	
II	85	MIDLAND AVENUE	3/4"	
II	93	MIDLAND AVENUE	3/4"	
II	97	MIDLAND AVENUE	3/4"	
II	103	MIDLAND AVENUE	1"	
II	105	MIDLAND AVENUE	1"	
II	107	MIDLAND AVENUE	3/4"	
II	109	MIDLAND AVENUE	1"	
II	115	MIDLAND AVENUE	1/2"	
II	117	MIDLAND AVENUE	1/2"	
II	118	MIDLAND AVENUE	1"	
II	119	MIDLAND AVENUE	1"	
II	125	MIDLAND AVENUE	3/4"	
II	129	MIDLAND AVENUE	1"	
II	132	MIDLAND AVENUE	3/4"	
II	133	MIDLAND AVENUE	1"	
II	134	MIDLAND AVENUE	1"	
II	136	MIDLAND AVENUE	3/4"	
II	137	MIDLAND AVENUE	1"	
II	138	MIDLAND AVENUE	1"	
II	141	MIDLAND AVENUE	1"	
II	142	MIDLAND AVENUE	1"	
II	144	MIDLAND AVENUE	1"	
II	146	MIDLAND AVENUE	1"	
II	148	MIDLAND AVENUE	1"	
II	66	OXFORD STREET	1"	
II	67	OXFORD STREET	1"	
II	68	OXFORD STREET	1"	
II	72	OXFORD STREET	1"	
II	73	OXFORD STREET	1"	
II	76	OXFORD STREET	1"	

CONSTRUCTION PHASE	HOUSE NUMBER	STREET NAME	REPORTED SERVICE SIZE	NOTES
II	79	OXFORD STREET	1"	
II	80	OXFORD STREET	1"	
II	83	OXFORD STREET	1"	
II	86	OXFORD STREET	1"	
II	87	OXFORD STREET	1"	
II	88	OXFORD STREET	1"	
II	89	OXFORD STREET	1"	
II	92	OXFORD STREET	1"	
II	95	OXFORD STREET	1"	
II	99	OXFORD STREET	1"	
II	14	RIDGEWOOD AVENUE	1"	COUNTY ROUTE 653
II	16	RIDGEWOOD AVENUE	1"	COUNTY ROUTE 653
II	20	RIDGEWOOD AVENUE	3/4"	COUNTY ROUTE 653
II	22	RIDGEWOOD AVENUE	1"	COUNTY ROUTE 653
II	24	RIDGEWOOD AVENUE	1"	COUNTY ROUTE 653
II	34	RIDGEWOOD AVENUE	1"	COUNTY ROUTE 653
II	35	RIDGEWOOD AVENUE	1"	COUNTY ROUTE 653
II	36	RIDGEWOOD AVENUE	1"	COUNTY ROUTE 653
II	37	RIDGEWOOD AVENUE	1"	COUNTY ROUTE 653
II	38	RIDGEWOOD AVENUE	1"	COUNTY ROUTE 653
II	40	RIDGEWOOD AVENUE	3/4"	COUNTY ROUTE 653
II	42	RIDGEWOOD AVENUE	1"	COUNTY ROUTE 653
II	44	RIDGEWOOD AVENUE	1"	COUNTY ROUTE 653
II	46	RIDGEWOOD AVENUE	1"	COUNTY ROUTE 653
II	101	RIDGEWOOD AVENUE	1"	TAP LOCATED ON LINDEN AVE
II	297	RIDGEWOOD AVENUE	1"	COUNTY ROUTE 653
II	306	RIDGEWOOD AVENUE	1"	COUNTY ROUTE 653
II	311	RIDGEWOOD AVENUE	1"	COUNTY ROUTE 653
II	314	RIDGEWOOD AVENUE	1"	COUNTY ROUTE 653
II	315	RIDGEWOOD AVENUE	1"	COUNTY ROUTE 653
II	320	RIDGEWOOD AVENUE	1"	COUNTY ROUTE 653
II	324	RIDGEWOOD AVENUE	1"	COUNTY ROUTE 653
II	325	RIDGEWOOD AVENUE	1"	COUNTY ROUTE 653
II	328	RIDGEWOOD AVENUE	1"	COUNTY ROUTE 653
II	329	RIDGEWOOD AVENUE	1"	COUNTY ROUTE 653
II	335	RIDGEWOOD AVENUE	1"	COUNTY ROUTE 653
II	345	RIDGEWOOD AVENUE	1 1/2"	COUNTY ROUTE 653
II	364	RIDGEWOOD AVENUE	1"	COUNTY ROUTE 653
II	365	RIDGEWOOD AVENUE	1"	COUNTY ROUTE 653
II	368	RIDGEWOOD AVENUE	1"	COUNTY ROUTE 653
II	388	RIDGEWOOD AVENUE	1"	COUNTY ROUTE 653
II	397	RIDGEWOOD AVENUE	1"	COUNTY ROUTE 653
II	409	RIDGEWOOD AVENUE	1"	COUNTY ROUTE 653
II	411	RIDGEWOOD AVENUE	1"	COUNTY ROUTE 653
II	412	RIDGEWOOD AVENUE	1 1/2"	COUNTY ROUTE 653
II	415	RIDGEWOOD AVENUE	1"	COUNTY ROUTE 653
II	418	RIDGEWOOD AVENUE	1"	COUNTY ROUTE 653
II	426	RIDGEWOOD AVENUE	1/4"	COUNTY ROUTE 653
II	428	RIDGEWOOD AVENUE	1 1/4"	COUNTY ROUTE 653
II	436	RIDGEWOOD AVENUE	1"	COUNTY ROUTE 653
II	438	RIDGEWOOD AVENUE	1"	COUNTY ROUTE 653

NOTICE
 THIS DRAWING AND ALL INFORMATION CONTAINED HEREIN IS AUTHORIZED FOR USE ONLY BY THE PARTY FOR WHOM THE WORK WAS CONTRACTED OR TO WHOM IT IS CERTIFIED.
 THIS DRAWING MAY NOT BE COPIED, REUSED, DISCLOSED, DISTRIBUTED, OR RELIED UPON FOR ANY OTHER PURPOSE WITHOUT THE WRITTEN CONSENT OF SUBURBAN CONSULTING ENGINEERS, INC.
 PER N.J.A.C. ELECTRONIC SUBMISSIONS NOT CONTAINING A VALID DIGITAL SEAL OR PAPER COPIES NOT CONTAINING A RAISED SEAL ARE NOT ORIGINALS AND MAY HAVE BEEN ALTERED.
 © COPYRIGHT 2019 SUBURBAN CONSULTING ENGINEERS, INC.™
 ALL RIGHTS RESERVED

REV PER CONTRACT MODIFICATIONS	D	06/18/2019	RAC	REW
REV PER NJDEP REVIEW COMMENTS	C	02/19/2019	RAC	REW
REV PER NJDEP REVIEW COMMENTS	B	02/11/2019	RAC	REW
REV PER CONTRACT MODIFICATIONS	A	12/17/2018	RAC	REW
DESCRIPTION	NO.	DATE:	BY:	CHK:
REVISIONS				

DRAWN BY:
RAC
05/01/2018
 CHECKED BY:
MKM
05/01/2018
 CHECKED BY:

ANDREW S. HOLT, PE
 NJ PROFESSIONAL ENGINEER
 LICENSE NO. 24GE03855400

 DATE: 05/01/2018

SC SE SUBURBAN CONSULTING ENGINEERS, INC.
 COA NO.: 24GA28037500
 21MFI00004200
 - Civil Engineers - Municipal Engineers -
 - Planners - Environmentalists - Land Surveyors -
 - Landscape Architects -
 96 US Highway 206, Suite 101 Flanders, NJ, 07836 - 973.398.1776
 2430 Highway 34, Bldg. A Suite 1R Wall, NJ, 08736 - 732.282.1776
 EXCELLENCE ♦ ECONOMY ♦ ENVIRONMENT

LEAD SERVICE WATER-LINE & FIRE HYDRANT REPLACEMENT RE-BID
BOROUGH OF GLEN RIDGE
ESSEX COUNTY, NEW JERSEY
SERVICE SCHEDULE IV

PROJECT NUMBER:
SCE-8859.011
 SCALE:
N.T.S.
 SHEET 6 OF 10
 REVISION D

E:\SCE\Glen Ridge - Lead Service and Hydrant\Re-bid\8859 Construction Details.dwg Jun 18, 2019 - 2:32pm rcarr SUBURBAN CONSULTING ENGINEERS, INC.

LEGEND

ADDITIONAL LEAD SERVICES

CONSTRUCTION PHASE	HOUSE NUMBER	STREET NAME	REPORTED SERVICE SIZE	NOTES
II	485	RIDGEWOOD AVENUE	1"	COUNTY ROUTE 653
II	486	RIDGEWOOD AVENUE	1"	COUNTY ROUTE 653
II	490	RIDGEWOOD AVENUE	1"	COUNTY ROUTE 653
II	496	RIDGEWOOD AVENUE	1"	COUNTY ROUTE 653
II	497	RIDGEWOOD AVENUE	1"	COUNTY ROUTE 653
II	498	RIDGEWOOD AVENUE	1"	COUNTY ROUTE 653
II	499	RIDGEWOOD AVENUE	1"	COUNTY ROUTE 653
II	501	RIDGEWOOD AVENUE	1"	COUNTY ROUTE 653
II	502	RIDGEWOOD AVENUE	1"	COUNTY ROUTE 653
II	503	RIDGEWOOD AVENUE	1"	COUNTY ROUTE 653
II	504	RIDGEWOOD AVENUE	1"	COUNTY ROUTE 653
II	505	RIDGEWOOD AVENUE	1"	COUNTY ROUTE 653
II	506	RIDGEWOOD AVENUE	1"	COUNTY ROUTE 653
II	507	RIDGEWOOD AVENUE	1"	COUNTY ROUTE 653
II	509	RIDGEWOOD AVENUE	1"	COUNTY ROUTE 654
II	510	RIDGEWOOD AVENUE	1"	COUNTY ROUTE 655
II	511	RIDGEWOOD AVENUE	1"	COUNTY ROUTE 656
II	514	RIDGEWOOD AVENUE	1"	COUNTY ROUTE 653
II	515	RIDGEWOOD AVENUE	1"	COUNTY ROUTE 653
II	517	RIDGEWOOD AVENUE	1"	COUNTY ROUTE 653
II	518	RIDGEWOOD AVENUE	1"	COUNTY ROUTE 653
II	519	RIDGEWOOD AVENUE	1"	COUNTY ROUTE 653
II	528	RIDGEWOOD AVENUE	3/4"	COUNTY ROUTE 653
II	532	RIDGEWOOD AVENUE	1"	COUNTY ROUTE 653
II	536	RIDGEWOOD AVENUE	1"	COUNTY ROUTE 653
II	538	RIDGEWOOD AVENUE	3/4"	COUNTY ROUTE 653
II	542	RIDGEWOOD AVENUE	3/4"	COUNTY ROUTE 653
II	579	RIDGEWOOD AVENUE	1"	COUNTY ROUTE 653
II	1	ROSWELL TERRACE	1"	
II	2	ROSWELL TERRACE	1"	
II	3	ROSWELL TERRACE	1"	
II	4	ROSWELL TERRACE	1"	
II	6	ROSWELL TERRACE	1"	
II	7	ROSWELL TERRACE	1"	
II	8	ROSWELL TERRACE	1"	
II	9	ROSWELL TERRACE	1"	
II	11	ROSWELL TERRACE	1"	
II	13	ROSWELL TERRACE	3/4"	
II	194	THOMAS STREET	5/8"	
II	196	THOMAS STREET	1"	
II	198	THOMAS STREET	1"	
II	202	THOMAS STREET	1"	
II	2	WASHINGTON PLACE	1"	
II	18	WASHINGTON PLACE	3/4"	
II	20	WASHINGTON PLACE	1"	
II	22	WASHINGTON PLACE	1"	
II	24	WASHINGTON PLACE	1"	
II	26	WASHINGTON PLACE	1"	
II	328	WASHINGTON STREET	1"	
II	340	WASHINGTON STREET	1"	
II	351	WASHINGTON STREET	1"	

CONSTRUCTION PHASE	HOUSE NUMBER	STREET NAME	REPORTED SERVICE SIZE	NOTES
III	2	ARDSLEY ROAD	1"	
III	4	ARDSLEY ROAD	1"	
III	5	ARDSLEY ROAD	1"	
III	6	ARDSLEY ROAD	1"	
III	7	ARDSLEY ROAD	1"	
III	8	ARDSLEY ROAD	1"	
III	9	ARDSLEY ROAD	1"	
III	10	ARDSLEY ROAD	1"	
III	11	ARDSLEY ROAD	1"	
III	12	ARDSLEY ROAD	1"	
III	14	ARDSLEY ROAD	1"	
III	459	BELLEVILLE AVENUE	1"	COUNTY ROUTE 506
III	461	BELLEVILLE AVENUE	1"	COUNTY ROUTE 506
III	463	BELLEVILLE AVENUE	1"	COUNTY ROUTE 506
III	467	BELLEVILLE AVENUE	1"	COUNTY ROUTE 506
III	471	BELLEVILLE AVENUE	1"	COUNTY ROUTE 506
III	20	BURNETT STREET	3/4"	
III	22	BURNETT STREET	3/4"	
III	26	BURNETT STREET	3/4"	
III	27	BURNETT STREET	3/4"	
III	29	BURNETT STREET	3/4"	
III	30	BURNETT STREET	3/4"	
III	33	BURNETT STREET	3/4"	
III	34	BURNETT STREET	3/4"	
III	35	BURNETT STREET	3/4"	
III	101	CARTERET STREET	1"	
III	103	CARTERET STREET	1"	
III	110	CARTERET STREET	1"	
III	112	CARTERET STREET	1"	
III	114	CARTERET STREET	1"	
III	116	CARTERET STREET	1"	
III	118	CARTERET STREET	1"	
III	120	CARTERET STREET	1"	
III	122	CARTERET STREET	1"	
III	126	CARTERET STREET	1"	
III	128	CARTERET STREET	1"	
III	132	CARTERET STREET	1"	
III	136	CARTERET STREET	1"	
III	138	CARTERET STREET	1"	
III	142	CARTERET STREET	1"	
III	144	CARTERET STREET	1"	
III	147	CARTERET STREET	1"	
III	152	CARTERET STREET	1"	
III	153	CARTERET STREET	1"	
III	158	CARTERET STREET	1"	
III	159	CARTERET STREET	1"	
III	162	CARTERET STREET	1"	
III	163	CARTERET STREET	1"	
III	166	CARTERET STREET	1"	
III	8	CROSS PLACE	3/4"	
III	46-8	EDGEWOOD ROAD	1"	

NOTICE
 THIS DRAWING AND ALL INFORMATION CONTAINED HEREIN IS AUTHORIZED FOR USE ONLY BY THE PARTY FOR WHOM THE WORK WAS CONTRACTED OR TO WHOM IT IS CERTIFIED.
 THIS DRAWING MAY NOT BE COPIED, REUSED, DISCLOSED, DISTRIBUTED, OR RELIED UPON FOR ANY OTHER PURPOSE WITHOUT THE WRITTEN CONSENT OF SUBURBAN CONSULTING ENGINEERS, INC.
 PER N.J.A.C. ELECTRONIC SUBMISSIONS NOT CONTAINING A VALID DIGITAL SEAL OR PAPER COPIES NOT CONTAINING A RAISED SEAL ARE NOT ORIGINALS AND MAY HAVE BEEN ALTERED.
 © COPYRIGHT 2019 SUBURBAN CONSULTING ENGINEERS, INC.™
 ALL RIGHTS RESERVED

REV PER CONTRACT MODIFICATIONS	D	06/18/2019	RAC	REW
REV PER NJDEP REVIEW COMMENTS	C	02/19/2019	RAC	REW
REV PER NJDEP REVIEW COMMENTS	B	02/11/2019	RAC	REW
REV PER CONTRACT MODIFICATIONS	A	12/17/2018	RAC	REW
DESCRIPTION	NO.	DATE:	BY:	CHK:
REVISIONS				

DRAWN BY:
RAC
05/01/2018

CHECKED BY:
MKM
05/01/2018

CHECKED BY:

ANDREW S. HOLT, PE
 NJ PROFESSIONAL ENGINEER
 LICENSE NO. 24GE03855400

DATE: 05/01/2018

SUBURBAN CONSULTING ENGINEERS, INC.
 COA No.: 24GA28037500
 21NFI070007001

- Civil Engineers - Municipal Engineers -
 - Landscape Architects -
 - Planners - Environmentalists - Land Surveyors -

96 US Highway 206, Suite 101 Flanders, N.J. 07836 - 973.398.1776
 2430 Highway 34, Bldg. A Suite 1R Wall, N.J. 08736 - 732.282.1776

EXCELLENCE ♦ ECONOMY ♦ ENVIRONMENT

LEAD SERVICE WATER-LINE & FIRE HYDRANT REPLACEMENT RE-BID
BOROUGH OF GLEN RIDGE
ESSEX COUNTY, NEW JERSEY

SERVICE SCHEDULE V

PROJECT NUMBER:
SCE-8859.011

SCALE:
N.T.S.

SHEET 7 OF 10

REVISION D

CONSTRUCTION PHASE	HOUSE NUMBER	STREET NAME	REPORTED SERVICE SIZE	NOTES
III	148	ESSEX AVENUE	1"	
III	154	ESSEX AVENUE	1"	
III	6	FERNCLIFF TERRACE	1"	
III	7	FERNCLIFF TERRACE	1"	
III	8	FERNCLIFF TERRACE	1"	
III	9	FERNCLIFF TERRACE	1"	
III	10	FERNCLIFF TERRACE	1"	
III	11	FERNCLIFF TERRACE	1"	
III	12	FERNCLIFF TERRACE	1"	
III	13	FERNCLIFF TERRACE	1"	
III	11	HAMILTON ROAD	1"	
III	50	HAMILTON ROAD	1"	
III	104	HAWTHORNE AVENUE	1"	
III	105	HAWTHORNE AVENUE	1"	
III	10	HIGH STREET	1"	
III	12	HIGH STREET	1"	
III	15	HIGH STREET	1"	
III	16	HIGH STREET	1"	
III	17	HIGH STREET	1"	
III	19	HIGH STREET	1"	
III	20	HIGH STREET	1"	
III	21	HIGH STREET	1"	
III	23	HIGH STREET	1"	
III	25	HIGH STREET	1"	
III	27	HIGH STREET	1"	
III	28	HIGH STREET	1"	
III	40	HIGH STREET	1"	
III	42	HIGH STREET	1"	
III	45	HIGH STREET	1"	
III	46	HIGH STREET	1"	
III	47	HIGH STREET	1"	
III	48	HIGH STREET	1"	
III	49	HIGH STREET	1"	
III	50	HIGH STREET	1"	
III	51	HIGH STREET	1"	
III	52	HIGH STREET	1"	
III	53	HIGH STREET	1"	
III	55	HIGH STREET	1"	
III	56	HIGH STREET	1"	
III	57	HIGH STREET	1"	
III	61	HIGH STREET	1"	
III	63	HIGH STREET	1"	
III	64	HIGH STREET	1"	
III	65	HIGH STREET	1"	
III	66	HIGH STREET	1"	
III	69	HIGH STREET	1"	
III	72	HIGH STREET	1"	
III	73	HIGH STREET	1"	
III	75	HIGH STREET	1"	
III	76	HIGH STREET	1"	
III	77	HIGH STREET	1"	

CONSTRUCTION PHASE	HOUSE NUMBER	STREET NAME	REPORTED SERVICE SIZE	NOTES
III	80	HIGH STREET	1"	
III	83	HIGH STREET	1"	
III	84	HIGH STREET	1"	
III	87	HIGH STREET	1"	
III	88	HIGH STREET	1"	
III	89	HIGH STREET	1"	
III	92	HIGH STREET	1"	
III	93	HIGH STREET	1"	
III	26	HILLCREST ROAD	1"	
III	163	HILLSIDE AVENUE	1"	
III	165	HILLSIDE AVENUE	1"	
III	169	HILLSIDE AVENUE	1"	
III	171	HILLSIDE AVENUE	1"	
III	173	HILLSIDE AVENUE	1"	
III	190	HILLSIDE AVENUE	1"	
III	193	HILLSIDE AVENUE	1"	
III	194	HILLSIDE AVENUE	1"	
III	195	HILLSIDE AVENUE	1"	
III	196	HILLSIDE AVENUE	1"	
III	197	HILLSIDE AVENUE	1"	
III	198	HILLSIDE AVENUE	1"	
III	199	HILLSIDE AVENUE	1"	
III	201	HILLSIDE AVENUE	1"	
III	202	HILLSIDE AVENUE	1"	
III	203	HILLSIDE AVENUE	1"	
III	204	HILLSIDE AVENUE	1"	
III	205	HILLSIDE AVENUE	1"	
III	206	HILLSIDE AVENUE	1"	
III	207	HILLSIDE AVENUE	1"	
III	209	HILLSIDE AVENUE	1"	
III	210	HILLSIDE AVENUE	1"	
III	211	HILLSIDE AVENUE	1"	
III	212	HILLSIDE AVENUE	1"	
III	11	MEAD TERRACE	1"	
III	13	MEAD TERRACE	1"	
III	2	MITCHELL PLACE	1"	
III	3	MITCHELL PLACE	1"	
III	4	MITCHELL PLACE	1"	
III	6	MITCHELL PLACE	1"	
III	7	MITCHELL PLACE	1"	
III	8	MITCHELL PLACE	1"	
III	9	MITCHELL PLACE	1"	
III	10	MITCHELL PLACE	1"	
III	11	MITCHELL PLACE	1"	
III	15	MITCHELL PLACE	1"	
III	17	MITCHELL PLACE	1"	
III	19	MITCHELL PLACE	1"	
III	21	MITCHELL PLACE	1"	
III	8	OAKWOOD AVENUE	1"	
III	12	OAKWOOD AVENUE	1"	
III	16	OAKWOOD AVENUE	1"	

NOTICE
 THIS DRAWING AND ALL INFORMATION CONTAINED HEREIN IS AUTHORIZED FOR USE ONLY BY THE PARTY FOR WHOM THE WORK WAS CONTRACTED OR TO WHOM IT IS CERTIFIED.
 THIS DRAWING MAY NOT BE COPIED, REUSED, DISCLOSED, DISTRIBUTED, OR RELIED UPON FOR ANY OTHER PURPOSE WITHOUT THE WRITTEN CONSENT OF SUBURBAN CONSULTING ENGINEERS, INC.
 PER N.J.A.C. ELECTRONIC SUBMISSIONS NOT CONTAINING A VALID DIGITAL SEAL OR PAPER COPIES NOT CONTAINING A RAISED SEAL ARE NOT ORIGINALS AND MAY HAVE BEEN ALTERED.
 © COPYRIGHT 2019 SUBURBAN CONSULTING ENGINEERS, INC.™
 ALL RIGHTS RESERVED

REV PER CONTRACT MODIFICATIONS	D	06/18/2019	RAC	REW
REV PER NJDEP REVIEW COMMENTS	C	02/19/2019	RAC	REW
REV PER NJDEP REVIEW COMMENTS	B	02/11/2019	RAC	REW
REV PER CONTRACT MODIFICATIONS	A	12/17/2018	RAC	REW
DESCRIPTION	NO.	DATE:	BY:	CHK:
REVISIONS				

DRAWN BY:
RAC
0501/2018
 CHECKED BY:
MKM
0501/2018
 CHECKED BY:

ANDREW S. HOLT, PE
 NJ PROFESSIONAL ENGINEER
 LICENSE NO. 24GE03855400

 DATE: 05/01/2018

SC SUBURBAN CONSULTING ENGINEERS, INC.
 CO. # 24GA28037500
 2131107000700
 - Civil Engineers - Municipal Engineers -
 - Landscape Architects -
 - Planners - Environmentalists - Land Surveyors -
 96 US Highway 206, Suite 101 Flanders, N.J. 07836 - 973.398.1776
 2430 Highway 34, Bldg. A Suite 1R Wall, N.J. 08756 - 732.282.1776
 EXCELLENCE ♦ ECONOMY ♦ ENVIRONMENT

LEAD SERVICE WATER-LINE & FIRE HYDRANT REPLACEMENT RE-BID
BOROUGH OF GLEN RIDGE
ESSEX COUNTY, NEW JERSEY
SERVICE SCHEDULE VI

PROJECT NUMBER:
SCE-8859.011
 SCALE:
N.T.S.
 SHEET 8 OF 10
 REVISION D

CONSTRUCTION PHASE	HOUSE NUMBER	STREET NAME	REPORTED SERVICE SIZE	NOTES
III	19	OAKWOOD AVENUE	1"	
III	20	OAKWOOD AVENUE	1"	
III	23	OAKWOOD AVENUE	1"	
III	27	OAKWOOD AVENUE	1"	
III	31	OAKWOOD AVENUE	1"	
III	32	OAKWOOD AVENUE	1"	
III	35	OAKWOOD AVENUE	1"	
III	36	OAKWOOD AVENUE	1"	
III	39	OAKWOOD AVENUE	1"	
III	65	OSBORNE STREET	3/4"	
III	110	OSBORNE STREET	1"	
III	5	OUTLOOK PLACE	1"	
III	1	RIDLEY COURT	1"	
III	6	RIDLEY COURT	1"	
III	9	RUDD COURT	1"	
III	11	RUDD COURT	1"	
III	12	RUDD COURT	1"	
III	13	RUDD COURT	1"	
III	14	RUDD COURT	1"	
III	15	RUDD COURT	1"	
III	16	RUDD COURT	1"	
III	17	RUDD COURT	1"	
III	18	RUDD COURT	1"	
III	1	SPENCER ROAD	1"	
III	5	SPENCER ROAD	3/4"	
III	30	SPENCER ROAD	3/4"	
III	33	SPENCER ROAD	3/4"	
III	35	STANFORD PLACE	1"	
III	36	STANFORD PLACE	1"	
III	37	STANFORD PLACE	1"	
III	38	STANFORD PLACE	1"	
III	39	STANFORD PLACE	1"	
III	40	STANFORD PLACE	1"	
III	41	STANFORD PLACE	1"	
III	42	STANFORD PLACE	1"	
III	43	STANFORD PLACE	1"	
III	44	STANFORD PLACE	1"	
III	45	STANFORD PLACE	3/4"	
III	37	STEPHEN STREET	3/4"	
III	39	STEPHEN STREET	3/4"	
III	40	STEPHEN STREET	3/4"	
III	41	STEPHEN STREET	3/4"	
III	42	STEPHEN STREET	3/4"	
III	7	SUMMIT STREET	1"	
III	1	TUXEDO ROAD	1"	
III	2	TUXEDO ROAD	1"	
III	3	TUXEDO ROAD	1"	
III	4	TUXEDO ROAD	1"	
III	5	TUXEDO ROAD	1"	
III	6	TUXEDO ROAD	1"	
III	7	TUXEDO ROAD	1"	

CONSTRUCTION PHASE	HOUSE NUMBER	STREET NAME	REPORTED SERVICE SIZE	NOTES
III	9	TUXEDO ROAD	1"	
III	10	TUXEDO ROAD	1"	
III	11	TUXEDO ROAD	1"	
III	12	TUXEDO ROAD	1"	
III	14	TUXEDO ROAD	1"	
III	15	TUXEDO ROAD	1"	
III	16	TUXEDO ROAD	1"	
III	244	WATCHUNG AVENUE	1"	COUNTY ROUTE 655
III	256	WATCHUNG AVENUE	1"	COUNTY ROUTE 655
III	258	WATCHUNG AVENUE	1"	COUNTY ROUTE 655
III	260	WATCHUNG AVENUE	3/4"	COUNTY ROUTE 655
III	42	WOODLAND AVENUE	1"	
III	45	WOODLAND AVENUE	1"	
III	48	WOODLAND AVENUE	1"	
III	49	WOODLAND AVENUE	1"	
III	52	WOODLAND AVENUE	1"	
III	57	WOODLAND AVENUE	1"	

FIRE HYDRANT REPLACEMENT SCHEDULE					
CONSTRUCTION PHASE	LABEL	MANUFACTURER	STYLE	LOCATION	NOTES
I	4	LUDLOW	L-75	98 BALDWIN STREET	
I	29	LUDLOW	L-75	14 CLARK STREET	
I	45A	MUELLER	M-1989	26 CLINTON ROAD	
I	272A	MUELLER	M-107	963 BLOOMFIELD AVENUE	COUNTY ROUTE 506
II	228A	LUDLOW	L-90	200 RIDGEWOOD AVENUE	COUNTY ROUTE 653
II	245A	MUELLER	M-2005	187 RIDGEWOOD AVENUE	COUNTY ROUTE 653
II	118A	LUDLOW	L-75	194 THOMAS STREET	
II	38	LUDLOW	L-75	176 BAY AVENUE	COUNTY ROUTE 654
II	48A	LUDLOW	L-75	307 RIDGEWOOD AVENUE	COUNTY ROUTE 653
II	75A	LUDLOW	L-75	34 MIDLAND AVENUE	
III	227A	MUELLER	M-2004	318 MAOLIS AVENUE	
III	143A	LUDLOW	L-75	11 MITCHELL PLACE	
III	117A	LUDLOW	L-75	960 BLOOMFIELD AVENUE	COUNTY ROUTE 506
III	103A	MUELLER	M-2004	96 DOUGLAS ROAD	
III	271A	MUELLER	M-2005	946 BLOOMFIELD AVENUE	COUNTY ROUTE 506

NOTICE
 THIS DRAWING AND ALL INFORMATION CONTAINED HEREIN IS AUTHORIZED FOR USE ONLY BY THE PARTY FOR WHOM THE WORK WAS CONTRACTED OR TO WHOM IT IS CERTIFIED.
 THIS DRAWING MAY NOT BE COPIED, REUSED, DISCLOSED, DISTRIBUTED, OR RELIED UPON FOR ANY OTHER PURPOSE WITHOUT THE WRITTEN CONSENT OF SUBURBAN CONSULTING ENGINEERS, INC.
 PER N.J.A.C. ELECTRONIC SUBMISSIONS NOT CONTAINING A VALID DIGITAL SEAL OR PAPER COPIES NOT CONTAINING A RAISED SEAL ARE NOT ORIGINALS AND MAY HAVE BEEN ALTERED.
 © COPYRIGHT 2019 SUBURBAN CONSULTING ENGINEERS, INC.™
 ALL RIGHTS RESERVED

REV PER CONTRACT MODIFICATIONS	NO.	DATE:	BY:	CHK:
REV PER CONTRACT MODIFICATIONS	D	06/18/2019	RAC	REW
REV PER NJDEP REVIEW COMMENTS	C	02/19/2019	RAC	REW
REV PER NJDEP REVIEW COMMENTS	B	02/11/2019	RAC	REW
REV PER CONTRACT MODIFICATIONS	A	12/17/2018	RAC	REW
REVISIONS				

DRAWN BY:
RAC
05/01/2018
 CHECKED BY:
MKM
05/01/2018
 CHECKED BY:

ANDREW S. HOLT, PE
 NJ PROFESSIONAL ENGINEER
 LICENSE NO. 24GE03855400

 DATE: 05/01/2018

SC SUBURBAN CONSULTING ENGINEERS, INC.
 COA NO.: 24GA28037500
 21MFI100004200
 - Civil Engineers - Municipal Engineers -
 - Landscape Architects -
 - Planners - Environmentalists - Land Surveyors -
 96 US Highway 206, Suite 101 Flanders, NJ. 07836 - 973.398.1776
 2430 Highway 34, Bldg. A Suite 1R Wall, N.J. 08736 - 732.282.1776
 EXCELLENCE ♦ ECONOMY ♦ ENVIRONMENT

LEAD SERVICE WATER-LINE & FIRE HYDRANT REPLACEMENT RE-BID
BOROUGH OF GLEN RIDGE
ESSEX COUNTY, NEW JERSEY
SERVICE SCHEDULE VII
AND FIRE HYDRANT SCHEDULE

PROJECT NUMBER:
SCE-8859.011
 SCALE:
N.T.S.
 SHEET 9 OF 10
 REVISION D

E:\SCE\Glen Ridge - Lead Service and Hydrant\Re-bid\8859 Construction Details.dwg Jun 18, 2019 - 2:33pm rcarr SUBURBAN CONSULTING ENGINEERS, INC.

**HUDSON-ESSEX AND PASSAIC COUNTY SOIL CONSERVATION DISTRICT
SOIL EROSION & SEDIMENT CONTROL NOTES**

- ALL SOIL EROSION AND SEDIMENT CONTROL PRACTICES ON THIS PLAN WILL BE CONSTRUCTED IN ACCORDANCE WITH THE "NEW JERSEY STANDARDS FOR SOIL EROSION AND SEDIMENT CONTROL" 7TH EDITION LAST REVISED DECEMBER 2017. THESE MEASURES WILL BE INSTALLED PRIOR TO ANY MAJOR SOIL DISTURBANCE OR IN THEIR PROPER SEQUENCE AND MAINTAINED UNTIL PERMANENT PROTECTION IS ESTABLISHED.
- ALL SOIL TO BE EXPOSED OR STOCKPILED FOR A PERIOD OF GREATER THAN 10 DAYS, AND NOT UNDER ACTIVE CONSTRUCTION, WILL BE TEMPORARILY SEEDED AND HAY MULCHED OR OTHERWISE PROVIDED WITH VEGETATIVE COVER. THIS TEMPORARY COVER SHALL BE MAINTAINED UNTIL SUCH TIME WHEREBY PERMANENT RESTABILIZATION IS ESTABLISHED.
- SEEDING DATES:** THE FOLLOWING SEEDING DATES ARE RECOMMENDED TO BEST ESTABLISH PERMANENT VEGETATIVE COVER WITHIN MOST LOCATIONS IN THE HEPCSD: SPRING - 3/1-5/15 AND FALL - 8/15 - 10/1
- PERMANENT VEGETATION TO BE IS TO SEEDED OR SODDED ON ALL EXPOSED AREAS WITHIN (10) DAYS AFTER FINAL GRADING. MULCH WILL BE USED FOR PROTECTION UNTIL GRADED.
- SEDIMENT FENCES ARE TO BE PROPERLY TRENCHED AND MAINTAINED UNTIL PERMANENT VEGETATIVE COVER IS ESTABLISHED.
- ALL STORM DRAINAGE INLETS SHALL BE PROTECTED BY ONE OF THE PRACTICES ACCEPTED IN THE STANDARDS, AND PROTECTION SHALL REMAIN UNTIL PERMANENT STABILIZATION HAS BEEN ESTABLISHED. STORM DRAINAGE OUTLET POINTS SHALL BE PROTECTED AS REQUIRED BEFORE THEY BECOME FUNCTIONAL.
- MULCH MATERIALS SHALL BE UN-ROTTED SMALL GRAIN STRAW APPLIED AT THE RATE OF 70 TO 90 POUNDS PER 1,000 SQUARE FEET AND ANCHORED WITH A MULCH ANCHORING TOOL OR NETTING TIE DOWN. OTHER SUITABLE MATERIALS MAY BE USED IF APPROVED BY THE SOIL CONSERVATION DISTRICT. THE USE OF ASPHALTIC MULCH BINDER IS PROHIBITED" AS PER N.J.A.C. 7:22-10.11 (F).
- ALL EROSION CONTROL DEVICES SHALL BE PERIODICALLY INSPECTED, MAINTAINED AND CORRECTED BY THE CONTRACTOR. ANY DAMAGE INCURRED BY EROSION SHALL BE RECTIFIED IMMEDIATELY.
- THE HUDSON-ESSEX-PASSAIC SOIL CONSERVATION DISTRICT WILL BE NOTIFIED IN WRITING AT LEAST 48 HOURS PRIOR TO ANY SOIL DISTURBING ACTIVITIES. FAX - (862) 333-4507 OR EMAIL - INFORMATION@HEPCSD.ORG
- THE APPLICANT MUST OBTAIN A DISTRICT ISSUED REPORT-OF-COMPLIANCE PRIOR TO APPLYING FOR THE CERTIFICATE OF OCCUPANCY OR TEMPORARY CERTIFICATE OF OCCUPANCY FROM THE RESPECTIVE MUNICIPALITY, NJ - DCA OR ANY OTHER CONTROLLING AGENCY. CONTACT THE DISTRICT AT 862-333-4505 TO REQUEST A FINAL INSPECTION, GIVING ADVANCED NOTICE UPON COMPLETION OF THE RESTABILIZATION MEASURES. A PERFORMANCE DEPOSIT MAY BE POSTED WITH THE DISTRICT WHEN WINTER WEATHER OR SNOW COVER PROHIBITS THE PROPER APPLICATION OF SEED, MULCH, FERTILIZER OR HYDRO-SEED.**
- PAVED ROADWAYS MUST BE KEPT CLEAN AT ALL TIMES. DO NOT UTILIZE A FIRE OR GARDEN HOSE TO CLEAN ROADS UNLESS THE RUNOFF IS DIRECTED TO A PROPERLY DESIGNED AND FUNCTIONING SEDIMENT BASIN. WATER PUMPED OUT OF THE EXCAVATED AREAS CONTAINS SEDIMENTS THAT MUST BE REMOVED PRIOR TO DISCHARGING TO RECEIVING BODIES OF WATER USING REMOVABLE PUMPING STATIONS, SUMP PITS, PORTABLE SEDIMENTATION TANKS AND/OR SILT CONTROL BAGS.
- ALL SURFACES HAVING LAWN OR LANDSCAPING AS FINAL COVER ARE TO BE PROVIDED TOPSOIL PRIOR TO RE-SEEDING, SODDING OR PLANTING. A DEPTH OF 5.0 INCHES, FIRMED IN PLACE, IS REQUIRED, AS PER THE STANDARDS FOR TOPSOILING AND LAND GRADING, LAST REVISED DECEMBER 2017.
- ALL PLAN REVISIONS MUST BE SUBMITTED TO THE DISTRICT FOR PROPER REVIEW AND APPROVAL.
- A CRUSHED STONE WHEEL CLEANING TRACKING-PAD IS TO BE INSTALLED AT ALL SITE EXITS USING 2 1/2 -1" CRUSHED ANGULAR STONE (ASTM 2 OR 3) TO A MINIMUM LENGTH OF 50 FEET AND MINIMUM DEPTH OF 6". ALL DRIVEWAYS MUST BE PROVIDED WITH CRUSHED STONE UNTIL PAVING IS COMPLETE.
- STEEP SLOPES INCURRING DISTURBANCE MAY REQUIRE ADDITIONAL STABILIZATION MEASURES. THESE "SPECIAL" MEASURES SHALL BE DESIGNED BY THE APPLICANT'S ENGINEER AND BE APPROVED BY THE SOIL CONSERVATION DISTRICT.
- THE HUDSON-ESSEX-PASSAIC SOIL CONSERVATION DISTRICT SHALL BE NOTIFIED, IN WRITING, FOR THE SALE OF ANY PORTION OF THE PROJECT OR FOR THE SALE OF INDIVIDUAL LOTS. NEW OWNERS' INFORMATION SHALL BE PROVIDED. ADDITIONAL MEASURES DEEMED NECESSARY BY DISTRICT OFFICIALS SHALL BE IMPLEMENTED AS CONDITIONS WARRANT.
- THE USE OF CALCIUM CHLORIDE, PETROLEUM PRODUCTS, OR OTHER CHEMICALS IS PROHIBITED FOR DUST CONTROL ON THE PLANS AS PER N.J.A.C. 7:22-10.11(M).

REQUIREMENTS FOR SILT FENCE:

- FENCE POSTS SHALL BE SPACED 8 FEET CENTER-TO-CENTER OR CLOSER. THEY SHALL EXTEND AT LEAST 2 FEET INTO THE GROUND AND EXTEND AT LEAST 2 FEET ABOVE GROUND. POSTS SHALL BE CONSTRUCTED OF HARDWOOD WITH A MINIMUM DIAMETER THICKNESS OF 1.5 INCHES.
- A METAL FENCE WITH 6 INCH OR SMALLER OPENINGS AND AT LEAST 2 FEET HIGH MAY BE UTILIZED, FASTENED TO THE FENCE POSTS, TO PROVIDE REINFORCEMENT AND SUPPORT TO THE GEOTEXTILE FABRIC WHERE SPACE FOR OTHER PRACTICES IS LIMITED AND HEAVY SEDIMENT LOADING IS EXPECTED.
- A GEOTEXTILE FABRIC, RECOMMENDED FOR SUCH USE BY THE MANUFACTURER, SHALL BE BURIED AT LEAST 6 INCHES DEEP IN THE GROUND. THE FABRIC SHALL EXTEND AT LEAST 2 FEET ABOVE THE GROUND. THE FABRIC MUST BE SECURELY FASTENED TO THE POSTS USING A SYSTEM CONSISTING OF METAL FASTENERS (NAILS OR STAPLES) AND A HIGH STRENGTH REINFORCEMENT MATERIAL (NYLON WEBBING, GROMMETS, WASHERS, ETC.) PLACED BETWEEN THE FASTENER AND THE GEOTEXTILE FABRIC. THE FASTENING SYSTEM SHALL RESIST TEARING AWAY FROM THE POST. THE FABRIC SHALL INCORPORATE A DRAWSTRING IN THE TOP PORTION OF THE FENCE FOR ADDED STRENGTH.

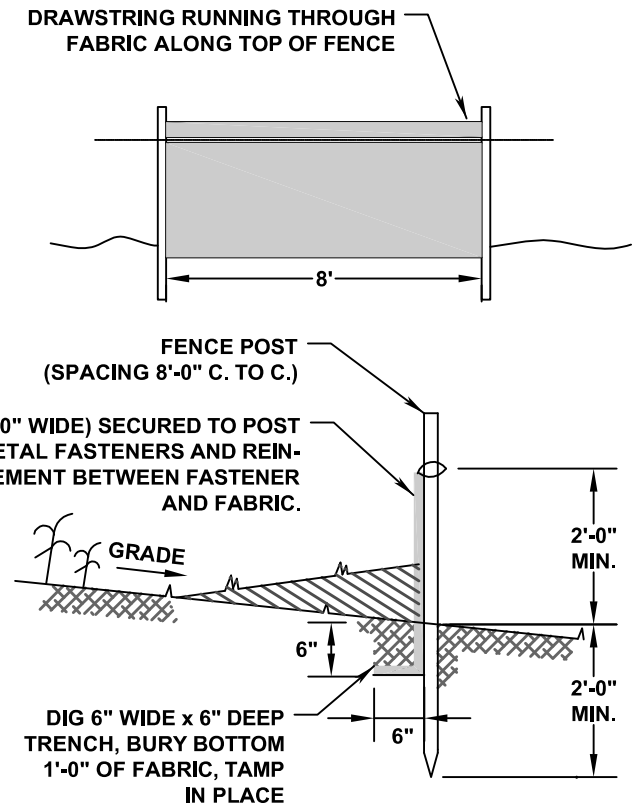

SEDIMENT FENCE DETAIL

N.T.S.

PROTECTED ROOT ZONE (PRZ) AND CRITICAL ROOT RADIUS (CRR)

- MEASURE THE DIAMETER AT BREST HEIGHT (DBH; 4.5 FEET ABOVE THE UPHILL SIDE OF THE TREE) IN INCHES.
- MULTIPLY MEASURE DBH BY 1.5 OR 1.0. EXPRESS THE RESULT IN FEET.
 - DBH X 1.5: CRR FOR OLDER, UNHEALTHY, AND SENSITIVE SPECIES.
 - DBH X 1.0: CRR FOR YOUNGER, HEALTHY, AND TOLERANT SPECIES.

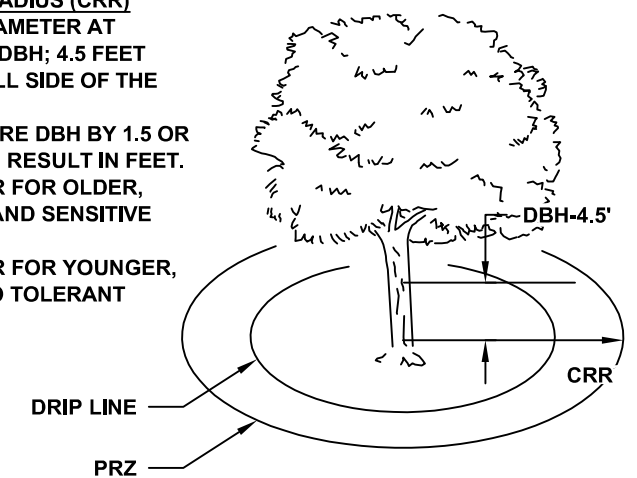

TREE PROTECTION

N.T.S.

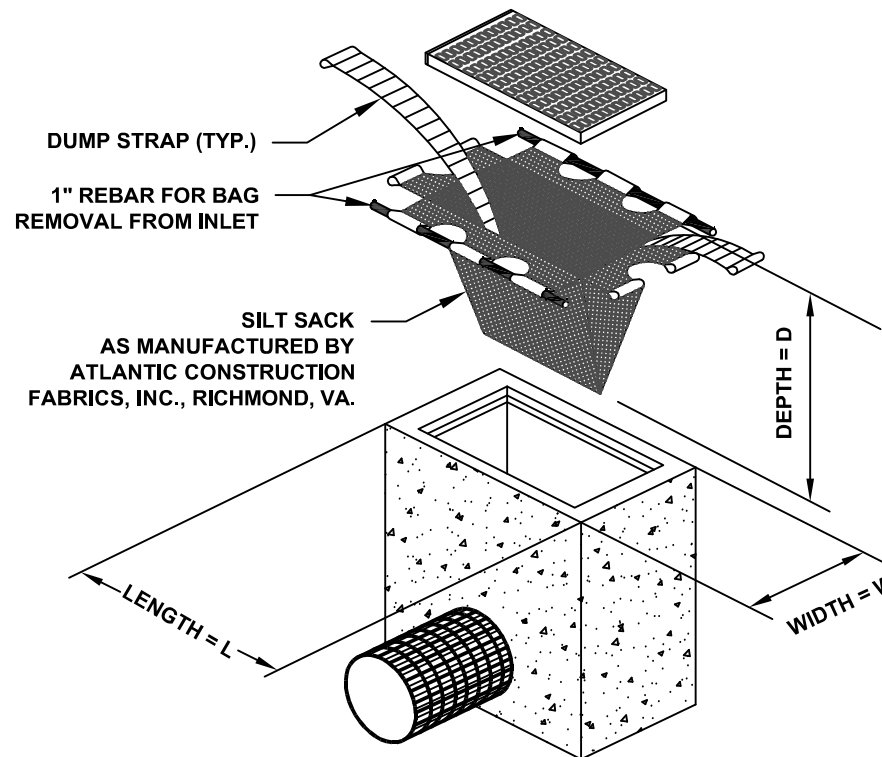

INLET PROTECTION DEVICE

N.T.S.

NOTICE
THIS DRAWING AND ALL INFORMATION CONTAINED HEREIN IS AUTHORIZED FOR USE ONLY BY THE PARTY FOR WHOM THE WORK WAS CONTRACTED OR TO WHOM IT IS CERTIFIED.
THIS DRAWING MAY NOT BE COPIED, REUSED, DISCLOSED, DISTRIBUTED, OR RELIED UPON FOR ANY OTHER PURPOSE WITHOUT THE WRITTEN CONSENT OF SUBURBAN CONSULTING ENGINEERS, INC.
PER N.J.A.C. ELECTRONIC SUBMISSIONS NOT CONTAINING A VALID DIGITAL SEAL OR PAPER COPIES NOT CONTAINING A RAISED SEAL ARE NOT ORIGINALS AND MAY HAVE BEEN ALTERED.
© COPYRIGHT 2019 SUBURBAN CONSULTING ENGINEERS, INC.™
ALL RIGHTS RESERVED

NO.	DESCRIPTION	DATE	BY:	CHK:
REV PER CONTRACT MODIFICATIONS	D	06/18/2019	RAC	
REV PER NJDEP REVIEW COMMENTS	C	02/19/2019	RAC	REW
REV PER NJDEP REVIEW COMMENTS	B	02/11/2019	RAC	REW
REV PER CONTRACT MODIFICATIONS	A	12/17/2018	RAC	REW
REVISIONS				

DRAWN BY:
RAC
05/01/2018
CHECKED BY:
MKM
05/01/2018
CHECKED BY:

ANDREW S. HOLT, PE
NJ PROFESSIONAL ENGINEER
LICENSE NO. 24GE03855400
DATE: 05/01/2018

SE SUBURBAN CONSULTING ENGINEERS, INC.
COA NO.: 24GA28037500
21NH100004200
- Civil Engineers - Municipal Engineers -
- Planners - Environmentalists - Land Surveyors -
96 US Highway 206, Suite 101 Flanders, NJ, 07836 - 973.398.1776
2430 Highway 34, Bldg. A Suite 1R Wall, N.J. 08736 - 732.282.1776
EXCELLENCE ♦ ECONOMY ♦ ENVIRONMENT

**LEAD SERVICE WATER-LINE & FIRE HYDRANT REPLACEMENT RE-BID
BOROUGH OF GLEN RIDGE
ESSEX COUNTY, NEW JERSEY**

SOIL EROSION & SEDIMENT CONTROL NOTES AND DETAILS

PROJECT NUMBER:
SCE-8859.011
SCALE:
N.T.S.
SHEET 10 OF 10
REVISION D